

Wall Plate Exhaust Fan.

Product datasheet



 **FANQUIP**

Wall Plate Exhaust Fan.

The Fanquip Wall Plate Exhaust Fans are designed and manufactured in Australia to operate in wide-ranging climatic conditions. Very versatile in their numerous and varied applications as exhaust or supply air fans. Well suited for environments requiring the removal of heat, steam and dust.

The Fanquip Wall Plate Exhaust Fan is available using adjustable pitch GRP (Glassfiber Reinforced Polypropylene) or cast aluminium airfoil impellers. The casing is fully welded steel construction with an inlet flare and outlet spigot, finished with an industrial polyester powder coat. The units are fitted with single-phase 240V or three-phase 415V heavy-duty motors of rugged construction, which incorporate sealed ball bearings to reduce operating noise.

There is a comprehensive range available with fan diameters ranging from 300mm to 1500mm.

Key features.



- ✓ Premium powder-coated steel casing
- ✓ Inlet and outlet finger guards
- ✓ IP55 Motor
- ✓ GRP adjustable pitch blades
- ✓ 2m lead with 3 pin IOA plug (240 models only)
- ✓ 3m lead with no plug (415V models only)

Applications.

The Wall Plate Exhaust Fan has an extensive range of applications.

Installation locations.

- ✓ Factories
- ✓ Warehouses
- ✓ Processing plants
- ✓ Machinery

Exhaust applications.

- ✓ Fumes
- ✓ Contaminated air
- ✓ Heat
- ✓ Steam

Options.

- Aluminium or stainless steel casings
- Hot dip galvanised finish
- Aluminium adjustable pitch blades
- Hazardous location rated – Exe, Exd, ExnA, Extd
- IP56 or IP66 motor
- Supply Air version available

Technical advice.

Fanquip have technical consultants to provide guidance on the specifications required to suit your Wall Plate Exhaust Fan use and application.

Warranty.

Twelve-month guarantee on the mechanical and electrical componentry subject to satisfactory maintenance with assessment and rectification, if any, to take place after return by the customer to Fanquip's workshop. Extended warranty options available on request.

Installation & maintenance.

The necessary procedures are outlined in the Fanquip installation, operation and maintenance instructions. These should be followed to ensure satisfactory performance and service life.

Wall Plate Exhaust Fan.

Product specifications.

Model No.	Fan Diameter (mm)	Motor Speed (RPM)	Motor Power (kW)	Voltage (V)	Full Load Amps (A)	Free Air Volume (L/S)	Noise* (dBA@3m)	Weight (kg)
4-30241	300	1440	0.37	240	2.40	654	49	20
4-30243	300	1440	0.37	415	1.03	654	49	20
4-40241	400	1440	0.55	240	3.80	1500	50	30
4-40243	400	1440	0.55	415	1.60	1500	50	30
4-50161	500	960	0.37	240	2.4	1550	51	50
4-50163	500	960	0.37	415	1.32	1550	51	50
4-50241	500	1440	0.75	240	4.5	2450	60	50
4-50243	500	1440	0.75	415	1.94	2450	60	50
4-60161	600	960	0.37	240	2.40	3274	60	65
4-60163	600	960	0.37	415	1.32	3274	60	65
4-60241	600	1440	1.10	240	6.60	4416	68	65
4-60243	600	1440	1.10	415	2.60	4416	68	65
4-80123	800	720	0.55	415	2.10	5679	59	85
4-80161	800	960	1.10	240	6.5	7000	65	85
4-80163	800	960	1.10	415	3	7000	65	85
4-10123	1000	720	1.50	415	4.2	10800	63	120
4-12123	1200	720	2.20	415	6	15000	69	150
4-15123	1500	720	3.00	415	7.8	22000	72	180

*Noise level is free field and indicative and should only be used to indicate relative values as actual figures depend on the fan and relevant field conditions.

Wall Plate Exhaust Fan.

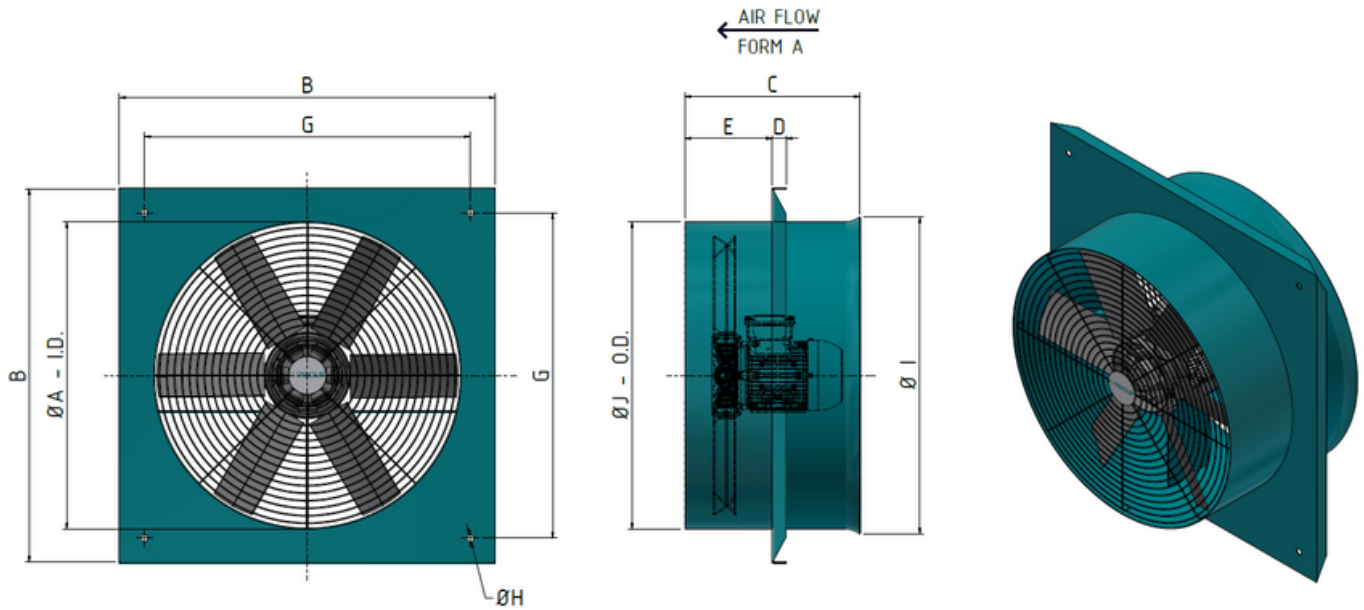

Product dimensions.

Model No.	A (mm)	B (mm)	C (mm)	D (mm)	E (mm)	G (mm)	H (mm)	I (mm)
300	310	380	350	25	175	326	10	330
400	410	510	350	25	175	438	10	450
500	510	610	350	20	175	530	10	545
600	610	760	350	30	175	670	12	645
800	810	960	400	25	220	900	12	845
1000	1010	1150	400	30	200	1070	12	1050
1200	1220	1360	450	30	225	1238	14	1260
1500	1525	1665	450	40	225	1558	14	1565
1800	1830	1970	610	40	305	1863	14	1870

*All sizes shown are standard. Subject to change without notice.

Wall Plate Exhaust Fan.

Accessories.

Accessory	Specifications
<p data-bbox="113 465 277 495">Roll Over Cowl</p> 	<ul data-bbox="810 495 1350 663" style="list-style-type: none">✓ 45° turn down for weather protection✓ For weather protection✓ Galvanised construction✓ Sizes ranging from 360mm to 1525mm square✓ Vermin mesh fitted
<p data-bbox="113 723 357 752">Variable Speed Drives</p> 	<ul data-bbox="810 824 1477 887" style="list-style-type: none">✓ 3 phase or single phase input. IP20 or IP66 and EMC compliant. User friendly interface.

Product datasheet.

Wall Plate Exhaust Fan.



Shop Wall Plate
Exhaust Fans



1300 224 308



www.fanquip.com.au